



Overview	110-113
Diesel Engine Coolant Filtration	110
Diesel Coolant Trends & Changes	110
Typical Coolant Filtration System	111
Coolant Filters & Design Features.....	112
Filter Media	113
Extended Service Coolant Filtration	114
Donaldson Blue™ Filters	114
Filtration Systems – Filter & Head Designs	115
Coolant Filters.....	116
Coolant Hoses.....	117
SCA/SCA+ Chemical Differences.....	117
Coolant Additives	118
Australia Coolant.....	119
Cooling System Maintenance.....	120-121
Test Strip Kit	120
Service intervals (flush/recharge).....	120
Proper Steps for Spin-on Coolant Replacements	121
Cooling System Problems.....	122



Diesel Engine Coolant Filtration

It is estimated that 40 - 50% of engine down-time is due to coolant system failure. Coolant system failure is avoidable. With today's diesel engines putting out more heat, cooling system care has become even more important than before. Your engine coolant battles rust, scale formation, acidity, foaming, silicate drop out and debris while it works to transfer heat and maintain the right operating conditions for optimal fuel economy.

Two filtration solutions are available for light and heavy EGR engines with SCR emissions devices. OEMs using heavy EGR coolant systems will see increased thermal cycling and accelerated coolant additive depletion. Coolant conditions may need to be checked frequently to ensure proper coolant chemical balance.

It's critical that you understand the exact make-up of coolant in your engine. The type of chemical is very specific to the job and operating environment.

Coolant System Considerations:

- Do you have traditional coolant that will require traditional supplemental coolant additives?
- Do you have an organic acid based coolant?
- Do you have an extended-service traditional coolant blend?

As you weigh your options, consider selecting a fully formulated antifreeze/coolant that meets either truck maintenance regulations for your region (U.S. Truck Maintenance Council (TMC) RP 329 or RP330 specifications). New glycerin formulae that meet the specifications use non-toxic glycerin derived from renewable sources that will effectively extend service intervals and provide ultimate protection in a more environmentally sound product.

Coolant testing should be done at least twice annually or when major coolant loss occurs.



Diesel Coolant Trends & Changes

- Increased thermal recycling will accelerate coolant additive depletion
- Long life coolant and filters
- Increased coolant testing (minimum 2x per year)
- Increased use of organic coolants

Coolant systems are referred to as a closed loop system with the filter operating in a side loop to the main flow. This means that a small percentage of flow goes through a filter that is designed to capture large contaminants. Coolant filters intended to maintain additive levels have an internal baffle with a small hole to control the rate of additive chemical release into the system.

Periodic drain and flushing to clean a system is important because while coolant filters capture large contaminants and release additive chemicals into the system, sediment can accumulate in the coolant system. Sediment can accumulate in the system and act as an insulator keeping heat in and prevent heat dissipation.



Typical Coolant Filtration Systems

There are many commercial options available for coolant filtration. Regardless of your preference, proper maintenance is essential to engine longevity. There are two popular choices for coolant systems – traditional or organic acid types.

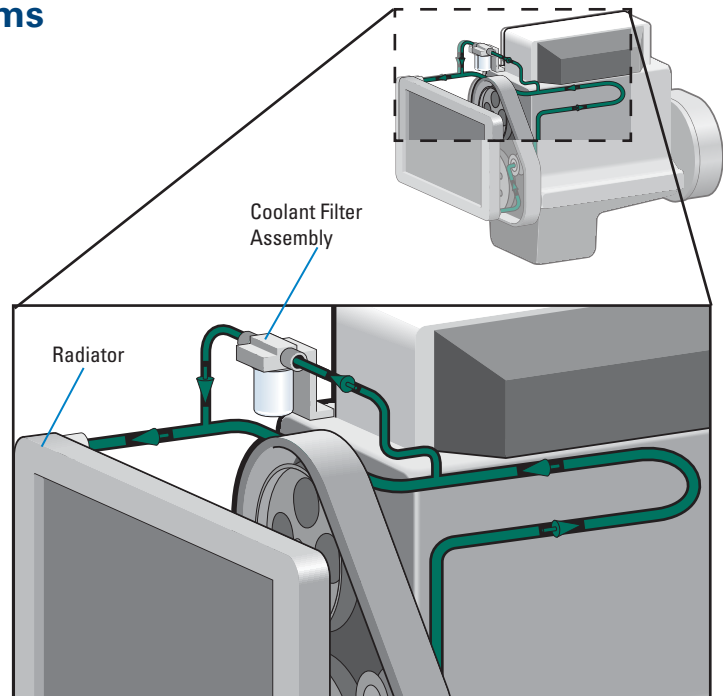

Traditional Coolant Systems

These systems are characterized by the use of ethylene glycol or propylene glycol in conjunction with a supplemental coolant additive. Typical coolant life is two years / ~300,000 miles / 480,000 kilometers). Engines using this chemical base typically recharge the chemical at every oil drain interval.

Donaldson filter options for traditional systems include:

- Pre-charged filters with
 - SCA chemicals
 - SCA+ chemicals
- Donaldson Blue™ filters with
 - slow-release additives
 - non-charged (blank) filter
user would add liquid SCA as needed

Organic Acid Coolant Systems

Organic acid technology (OAT) is a choice for those interested in long life or extended service coolant. OAT systems are not chemically compatible with the traditional SCA/SCA+ coolant systems. Typical coolant life is four years / ~600,000 miles / 965,000 kilometers. Engines using this chemical base typically recharge the coolant at ½ the life of the coolant.

Donaldson filters for OAT systems include Donaldson Blue™ (non-chemical).

Hybrid Coolant Systems

This type of coolant system is a blend of traditional and OAT coolant technologies. They may offer improved protection and extended life characteristics over OAT. The expected life is same as OAT, but with an annual recharge (vs. ½).

Donaldson filters for Hybrid systems include Donaldson Blue™ (non-chemical).



Coolant Filters

Coolant system filters are typically partial-flow (by-pass) filters, with less than 10% of the coolant flow circulating through the filter at any given time.

Donaldson coolant filter offering allows you to choose the method that suits your maintenance practices and schedules.

Donaldson coolant filters are designed to work in a wide variety of operating environments and meet the service requirements of the majority of heavy-duty diesel engines.

Use of the correct filter is important to maintain the proper balance in the system to prevent over concentration (silicate drop out) or under concentration which leads to corrosion, liner pitting or other system problems.

There are four types of Donaldson coolant additive filter types available.

- The pre-charge filter which contains enough coolant additive to initially charge the cooling system and to allow for depletion to the first service interval.
- The standard charge spin-on filters which contain adequate chemical additive to maintain cooling systems between service intervals.
- Blank filters which contain no chemical additive and can be used for the following systems, cooling systems maintained by liquid additive, systems using long life coolants which require no additive, or on overcharged systems to bring the additive level back to a normal range. Blank filters are not intended to be used with water-only systems.
- The fourth type is Donaldson Blue™ with time release spin-on series which release small amounts of additive into the system over a period of time to maintain proper additive levels.



Coolant Spin-on Design Features

The Donaldson spin-on coolant filter has three heavy-duty features: a thread-plate profile for strength, rolled threads which are cleaner, and the robust full tuck seam for extra durability. The Donaldson tapered thread profile simplifies installation and prevents cross threading. Not all filters have an inner seal between the thread plate and end plate. Donaldson's seal is constructed of molded elastomer which is designed to withstand extreme cold and heat.

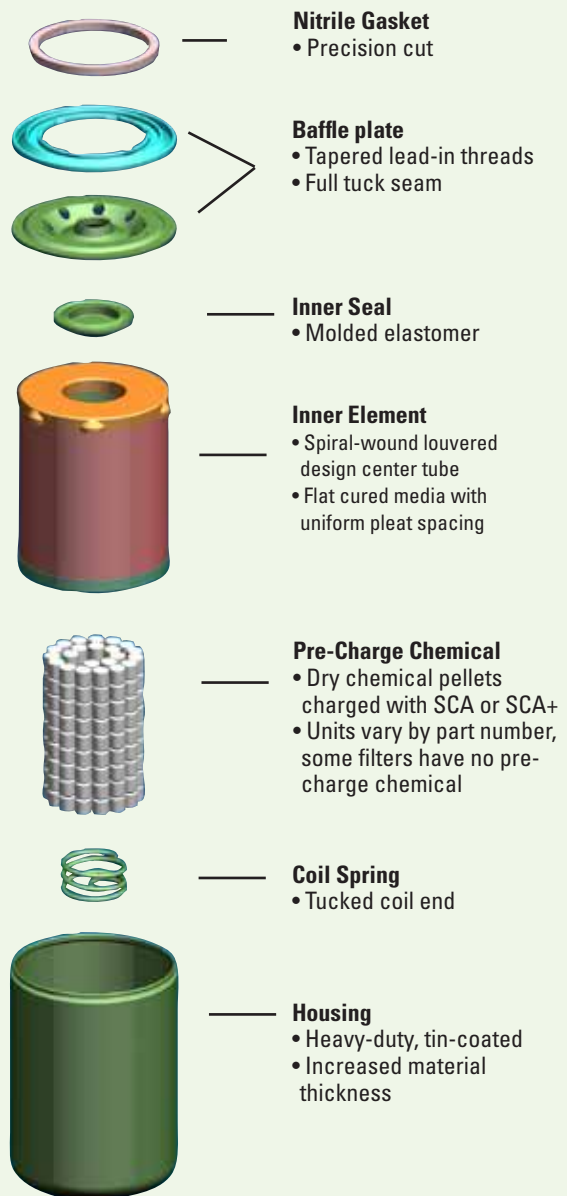



Filter Media

Coolant filter medias are available to meet the most stringent of engine system design challenges. Donaldson engineers have a history of development and application of media technology that exceeds application cleanliness and service life expectations.

Cellulose Media

Engine coolant filter media is most commonly a pleated cellulose base material. This media effectively combines an application's efficiency and capacity requirements while maintaining cost effectiveness.

Traditional based coolant systems often use this media when service intervals are maintained with non-extended oil drain intervals.

How it Works

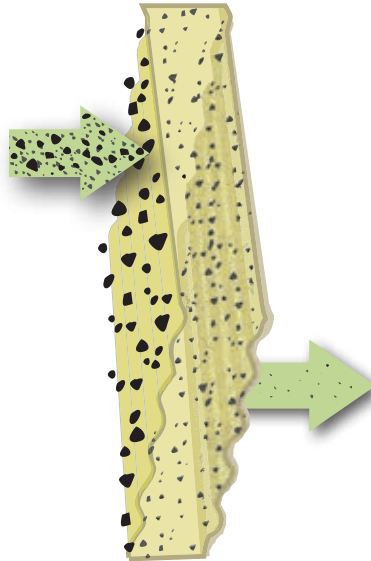

SEM 100x SEM 600x

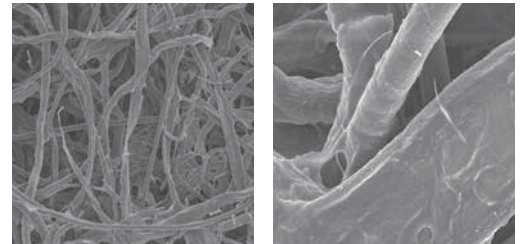

Media Image



Synteq™ Media (full synthetic)

Extended life intervals require micro-fiberglass synthetic media trademarked Synteq™. This media provides enhanced durability for extended drain intervals while maintaining or improving efficiency and capacity. Donaldson Synteq coolant media also offers lower restriction, ensuring component protection over a larger range of engine conditions.

How it Works

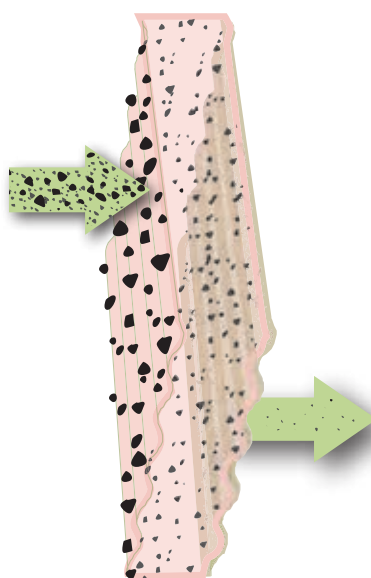

SEM 100x

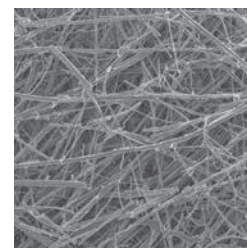

SEM 600x

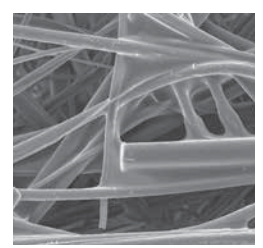

Media Image

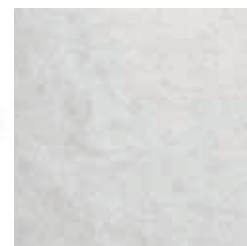



Donaldson

BLUE™

with Additive Replenishment Technology

Donaldson Blue™ coolant filters with additive replenishment technology maintain cooling system balance through a controlled release of additives. It allows you to extend your traditional diesel engine coolant maintenance interval up to once a year or 150,000 mile / 195,000 km.

Additive Replenishment Built into the Filter

- Maintains healthy coolant condition
- Reduces maintenance costs
- Uses time-release additives to replenish coolant
- For use with supplemental coolant additive (SCA) chemistry (Ethylene Glycol or Propylene Glycol)

Direct Replacement to Standard Filter

- No system modifications or special maintenance required
- Unique design eliminates metal coil spring in bottom of housing
- No special disposal requirements
- For Caterpillar, Detroit Diesel, Volvo and Cummins engine applications

Synteq™ Filtration Media

- More effective than standard cellulose filter media
- Improved coolant flow
- Increased capacity to allow extended service interval

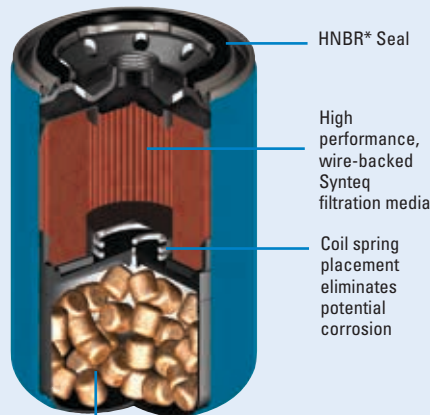

HNBR* Seal

High performance, wire-backed Synteq filtration media

Coil spring placement eliminates potential corrosion

Container releases a concentrated blend of additives through diffusion
For traditional coolants - Ethylene Glycol or Propylene Glycol

How Additive Replenishment Technology Works

Coolant enters the filter just as the standard coolant filters. Inside the filter, a controlled release of additives is introduced to maintain coolant chemistry and chemistry.

The coolant continues a normal flow to the media cartridge and passes through our Synteq filter media. Clean, replenished coolant is returned to the engine.

This additive replenishment process is optimized to effectively maintain the healthy condition of the coolant and allows you to extend your coolant maintenance interval.

* HNBR = Hydrogenated Nitrile Butadiene Rubber
HNBR is classified by ASTM as a DH-type polymer

Fits Coolant Filter	Part No.
All	DBC4088
Volvo M16 x 1.5 Thd	DBC4089

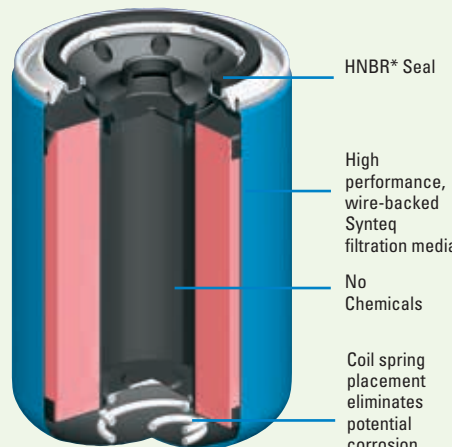

HNBR* Seal

High performance, wire-backed Synteq filtration media

No Chemicals

Coil spring placement eliminates potential corrosion

Donaldson

BLUE™

Non-chemical Donaldson Blue filters will go the distance of your coolant; for Organic Additive Technology and Extended Service Coolant Users

Fits Coolant	Part No.
All	DBC4085
Volvo M16 x 1.5 Thd	
3969696	DBC4086 - 5.35" L
20458771	DBC4081 - 4.20" L

Upgrade from a Competitive Filter to Donaldson Blue™



Donaldson Blue™	Fleetguard	Baldwin	Luber-finer	Wix	Primary Application
DBC4081	WF2129	B5145	LFW5142XL	24091	Extended Service 150K non-chemical coolant filter, Volvo
DBC4085	WF2123	B5090	LFW4685XL	24084	Extended Service 150K non-chemical coolant filter
DBC4086	WF2130	B5144	LFW5141XL	—	Extended Service 150K non-chemical coolant filter, Volvo
DBC4088	WF2131	BW5200	LFW6500	24088	Extended Service 150K coolant with chemical filter
DBC4089	WF2128	—	LFW6501	24090	Extended Service 150K coolant, Volvo



Handles Coolant Systems up to 400 Gallons / 1500 Liters

The Donaldson remote mount head is designed to fit all our spin-on filters with a 11/16" -16 threads. The bracket can be mounted remotely.

Head Part No.
P550840

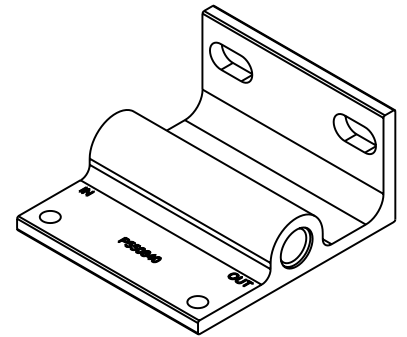
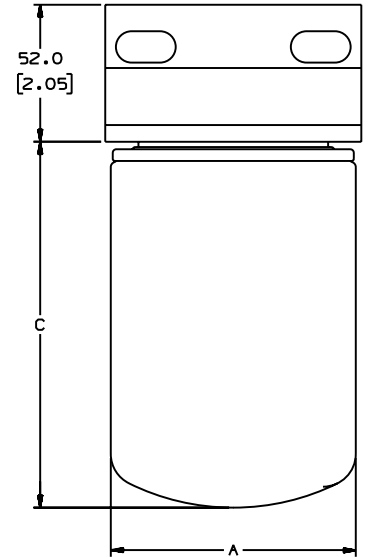
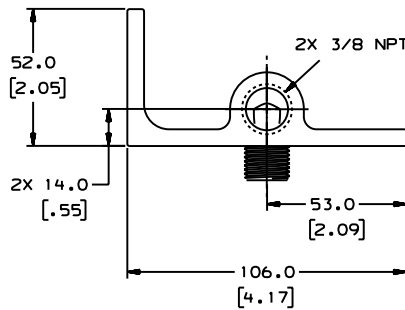
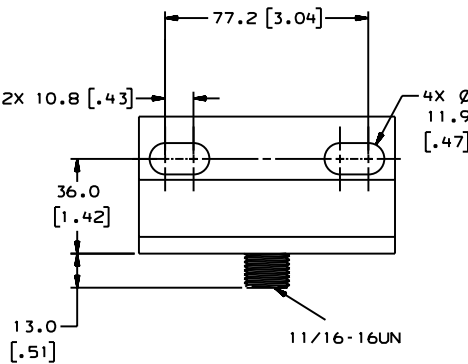
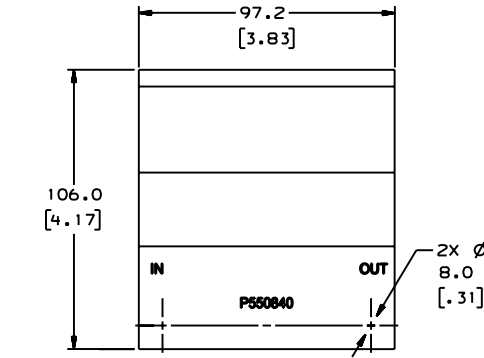

Filter Selection Chart

Outer Diameter		(C) Filter Length		Media Type	Efficiency @ Micron	Chemical Units	SCA Filter Part No.	SCA+ Filter Part No.	
in	mm	in	mm						
3.66	93	4.21	107	Cellulose	99% @ 50	2 Units	N/A	P552070	
				Cellulose	99% @ 50	4 Units	P554071	P552071	
				Cellulose	99% @ 50	6 Units	P554072	P552072	
		5.35	135	Synteq	99% @ 14	Extended Service No Chemical	DBC4085		
						Extended Service, Time Release	DBC4088	N/A	
				Cellulose	99% @ 50	8 Units	P554073	P552073	
				Cellulose	99% @ 50	12 Units	P554074	P552074	
				Cellulose	99% @ 50	15 Units	P554075	P552075	
				Cellulose	99% @ 50	Standard Service No Chemical	P554685		
				Cellulose	99% @ 50	23 Units	N/A	P552076	



Spin-On Coolant Filters

Thread	OD		Length		Part No.	Part Description	Efficiency @ Micron	Primary Application	GSKT O.D.		GSKT I.D.	
	IN	MM	IN	MM					IN	MM	IN	MM
Non-Chemical Filters												
11/16 - 16	3.66	93	5.35	136	P554685	Spin-on non-chemical	50% @ 20	CUMMINS	2.81	71	2.42	61
3/4-20	3.67	93	5.32	135	P551309	Spin-on non-chemical	50% @ 25	MACK	2.81	71	2.42	61
M36 x 2	3.69	94	5.76	146	P550867	Spin-on non-chemical	99% @ 50	With Synteq	3.66	93	3.17	81
SCA Filters												
1-16	4.28	109	5.78	147	P554422	Spin-on 11 Units - SCA		MACK 25MF422	3.89	99	3.55	90
11/16 - 16	3.66	93	4.21	107	P554071	Spin-on 4 Units - SCA	50% @ 25	CUMMINS 3315116	2.81	71	2.42	61
	3.66	93	4.21	107	P554072	Spin-on 6 Units - SCA	50% @ 25	CUMMINS 3318201	2.81	71	2.42	61
	3.66	93	5.35	136	P554073	Spin-on 8 Units - SCA	50% @ 25	CUMMINS 3315115	2.81	71	2.42	61
	3.66	93	5.35	136	P554074	Spin-on 12 Units - SCA	50% @ 25	CUMMINS 3316053	2.81	71	2.42	61
	3.66	93	5.35	136	P554075	Spin-on 15 Units - SCA	50% @ 25	CUMMINS 3318318	2.81	71	2.42	61
	3.66	93	7.89	200	P552055	Spin-on 23 Units - SCA	50% @ 20	CUMMINS 3305371	2.81	71	2.42	61
	3.69	94	5.32	135	P552106	Spin-on 4 Units - SCA	50% @ 25	NAVISTAR	2.83	72	2.46	62
	3.69	94	5.44	138	P552088	Time-release Spin-on, 43 Units	99% @ 25	NALCO NF2008, PENRAY NR2088, FLEET-GUARD WF2131, 10-20 gal capacity	2.85	72	2.42	61
3/4-20	3.66	93	5.35	136	P554860	Spin-on 8 Units - SCA	99% @ 50	MACK 25-MF-314A	2.81	71	2.42	61
M16 x 1.5	3.66	93	5.35	136	P552096	Spin-on 5 Units - SCA	99% @ 50	VOLVO 1661964 ,1699830	2.81	71	2.42	61
	3.66	93	5.35	136	P554019	Spin-on 8 Units - SCA	99% @ 50	VOLVO 3945411	2.81	71	2.42	61
SCA+ Filters												
11/16 - 16	3.66	93	7.87	200	P552076	Spin-on 23 Units - SCA+	50% @ 20	CUMMINS 3318319	2.83	72	2.44	62
	3.69	94	4.15	105	P552071	Spin-on 4 Units - SCA+	50% @ 25	CUMMINS 3315116	2.83	72	2.46	62
	3.7	94	4.07	103	P552070	Spin-on 2 Units - SCA+	50% @ 25	CUMMINS 3318157	2.85	72	2.45	62
	3.7	94	4.07	103	P552072	Spin-on 6 Units - SCA+	50% @ 25	CUMMINS 3318201	2.85	72	2.45	62
	3.7	94	5.32	135	P552073	Spin-on 8 Units - SCA+	50% @ 25	CUMMINS 3315115	2.85	72	2.45	62
	3.7	94	5.32	135	P552074	Spin-on 12 Units - SCA+	50% @ 25	CUMMINS 3316053	2.85	72	2.45	62
	3.7	94	5.32	135	P552075	Spin-on 15 Units - SCA+	50% @ 25	CUMMINS 3318318	2.85	72	2.45	62
M36 x 2	3.69	94	5.76	146	P550866	Spin-on 8 Units - SCA+	99% @ 50	Cummins Extended Life Coolant	3.66	93	3.17	81
Donaldson Blue™ Extended Service Filters												
11/16 - 16	3.66	93	5.33	135	DBC4085	Spin-on non-chemical	99% @ 14	EXTENDED SERVICE FILTER	2.83	72	2.44	62
M16 x 1.5	3.66	93	4.20	107	DBC4081	Spin-on non-chemical	99% @ 50	EXTENDED SERVICE FILTER	2.83	72	2.44	62
M16 x 1.5-6H	3.66	93	5.35	136	DBC4086	Spin-on non-chemical	99% @ 14	EXTENDED SERVICE FILTER VOLVO	2.73	72	2.44	62
11/16 - 16	3.67	93	5.35	136	DBC4088	Spin-on, additive replenishment technology	99% @ 14	EXTENDED SERVICE COOLANT	2.83	72	2.44	62
M16 x 1.5-6H	3.66	93	5.35	136	DBC4089	Spin-on, additive replenishment technology	99% @ 14	EXTENDED SERVICE COOLANT, VOLVO	2.83	72	2.44	62

Coolant Hose - 3 & 4 Ply

Designed to withstand extremes in operating temperatures ranging from -65°F to 350°F (-54°C to 177°C).

3-ply hose 3 ft./0.91m lengths

3-ply hose is reinforced with three layers of polyester fabric and coated with a unique silicone elastomer.



Size (inner dia.)		Part No.	Nominal O.D.		Recommended Clamp	
in	mm		in	mm	Lined	Constant Torque
0.63	16	P171371	0.95	24	P532921	N/A
0.75	19	P171372	1.08	27	P532923	N/A
0.88	22	P171373	1.20	30	P532923	N/A
1.00	25	P171374	1.33	34	P532923	N/A
1.13	29	P171375	1.45	37	P532924	N/A
1.25	32	P171376	1.90	48	P532924	N/A
1.38	35	P171377	1.70	43	P115200	N/A
1.50	38	P171378	1.83	46	P115200	N/A
1.63	41	P171379	1.95	50	P115200	N/A
1.75	44	P171380	2.08	53	P115200	N/A
2.00	51	P171381	2.33	59	P115200	P532925
2.25	57	P171382	2.58	66	P115201	P532925
2.38	60	P171383	2.70	69	P115201	P532925
2.50	64	P171384	2.83	72	P115201	P532925
2.63	67	P171385	2.95	75	P143422	P532925
2.75	70	P171386	3.08	78	P143422	P532926
3.00	76	P171387	3.33	85	P143422	P532926
3.50	89	P171388	4.83	123	P115202	P532927
4.00	102	P171389	4.33	110	P115203	P532928

4-ply hose 3 ft./0.91m lengths

4-ply hose is reinforced with an added layer of polyester fabric and provides even greater resistance to abrasion and rubbing.



Size (inner dia.)		Part No.	Nominal O.D.		Recommended Clamp	
in	mm		in	mm	Lined	Constant Torque
1.00	25	P171390	1.40	36	P532924	N/A
1.50	38	P171391	1.90	48	P115200	N/A
2.00	51	P171392	2.40	61	P115201	P532925
2.50	64	P171394	2.89	73	P115201	P532925
2.75	70	P171395	3.15	80	P143422	P532926

SCA/SCA+ Chemical Differences

What are the SCA chemicals and how do they do their job?

Nitrite is the key chemical component in SCA cooling system treatment. Nitrite provides protection against cavitation, erosion, and it inhibits corrosion. Nitrate also provides corrosion protection to aluminum and solder.

Borate functions as an alkaline buffer to prevent acidity and controls pH.

MBT (Mercaptabenzothiazole) provides a plating effect on all copper and copper alloys, protecting them from direct contact with coolant and oxygen, and subsequent corrosion.

Silicate reduces corrosion of ferrous metals and is an effective aluminum corrosion inhibitor.

SCA may be substituted for DCA2 and BTE

SCA+ may be substituted for DCA4 and BTA Plus

While the chemical composition of SCA+ Cooling System Treatment features some of the same chemicals, there are differences.

Molybdate and Nitrite are combined to provide cavitation erosion protection and inhibit corrosion.

Silicate reduces corrosion of ferrous metals and is an effective aluminum corrosion inhibitor. Phosphate functions as an alkaline buffer to prevent acidity and controls pH.

Donaldson SCAs combat a whole series of coolant system problems including, rust, scale from minerals, acidity from antifreeze, the intrusion of air fuel and oil to coolant, pitting of engine parts from cavitation, foaming from coolant aeration and silicate drop-out from over-concentration.



Coolant Additives

Supplemental Coolant Additive (SCA and SCA+) is available in many sizes, from a pint to a 55-gallon drum.



Cooling System Treatment

Size	SCA	SCA+
1 Pt./ 0.47 L.	X006136	X007099
1 Qt./ .95 L.	X007036	
2 Qt./ 1.89 L.	X007037	X007100
1 Gal./ 3.79 L.	X007038	
5 Gal./ 18.93 L.	X006137	X007101
Drum: 55 Gal./ 208.2 L.	X006138	X007102

Re-charge Cooling System after Flush

Cooling System Capacity Add this amount of SCA or SCA+

5-7 gallons	18.9-26.5 liters	2 pints	0.9 liters
8-11 gallons	30.3-41.6 liters	3 pints	1.4 liters
11-15 gallons	41.6-56.8 liters	4 pints	1.9 liters
16-20 gallons	60.6-75.7 liters	5 pints	2.4 liters
21-30 gallons	79.5-113.6 liters	1 gal	3.8 liters
31-50 gallons	117.3 to 189.3 liters	1.5 gal	5.7 liters
51-75 gallons	193.0-283.9 liters	2.25 gal	8.5 liters
76-100 gallons	287.7-378.5 liters	3 gal	11.4 liters
101-150 gallons	382.3-567.8 liters	4.5 gal	17.0 liters
151-200 gallons	571.5-757.0 liters	6 gal	22.7 liters
201-250 gallons	760.8-946.3 liters	7.5 gal	28.4 liters
251-300 gallons	950.0-1135.5 liters	9 gal	34.1 liters
301-350 gallons	1139.3-1324.8 liters	10.5gal	39.7 liters
351-400 gallons	1328.5-1514.0 liters	12gal	45.4 liters



Thermo-Tech Heavy-Duty Coolant

Available in Australia Only

Note:

Product featured on this page is available in Australia only.
Contact Donaldson Australasia Customer Service on 1800 345 837 to find a distributor near you.
Further information can be found on www.donaldsontoolbox.com.au

Donaldson's Thermo-Tech range covers all of your fleet coolant needs, including conventional heavy-duty technologies, environmentally friendly organic product, and our superior long life propylene glycol hybrid offering.

Thermo-Tech PG is the premium coolant in our range and (if required) is fully compatible with all other Propylene Glycol (PG), Ethylene Glycol (EG) or Organic Acid Technology (OAT) coolants. It is designed for use with all types of diesel, petrol and LPG engines and offers the following features:

- Premixed and ready to use
- Extended life
- Lasts up to 6 years, 12,000 hours or 1,000,000 kilometres in heavy-duty applications
- Lasts up to 5 years or 250,000 kilometres in 4WDs and passenger vehicles
- Superior corrosion protection



Donaldson Thermo-Tech PG is available in:

	PREMIX	CONCENTRATE
5 Litres	P903106	-
20 Litres	P903107	-
205 Litres	P903108	-
1000 Litres	P903109	-

Contains 495g/L propylene glycol

Thermo-Tech EG is an Ethylene Glycol based coolant designed for use with all types of diesel, petrol and LPG engines. Thermo-Tech EG is a conventional coolant based on a proprietary formulation of corrosion inhibitors and offers the following features:

- No need for supplemental coolant additives (SCA's) upon initial fill
- Lasts up to 2 years, 3,000 hours or 320,000 kilometres in heavy-duty applications
- Lasts up to 3 years or 100,000 kilometres in 4WDs and passenger vehicles
- Compatible with other conventional coolants (if being used as a top-up)
- Specially formulated to protect heavy-duty wet sleeve liners



Donaldson Thermo-Tech EG is available in:

	PREMIX	CONCENTRATE
5 Litres	P903100	-
20 Litres	P903101	P903104
205 Litres	P903102	P903105
1000 Litres	P903103	-

Premix contains 545g/L ethylene glycol

Thermo-Tech OAT (Organic Acid Technology) is a water based coolant designed for use with all types of diesel, petrol and LPG engines. Thermo-Tech OAT is a glycol free coolant based on a proprietary formulation of corrosion inhibitors & offers the following features:

- No need for supplemental coolant additives (SCAs) upon initial fill
- Lasts up to 4 years, 12,000 hours or 1,000,000 kilometres in heavy-duty applications
- Lasts up to 3 years or 100,000 kilometres in 4WDs and passenger vehicles
- Specially formulated to protect heavy-duty wet sleeve liners
- Organic formula is free from glycol, amine, borate, phosphate, nitrates, nitrites & silicate
- Compatible with other organic coolants (if being used as a top-up)



Donaldson Thermo-Tech OAT is available in:

	PREMIX	CONCENTRATE
5 Litres	P903110	-
20 Litres	P903111	P903114
205 Litres	P903112	P903115
1000 Litres	P903113	-

Thermo-Tech Radiator Flush is an engine cooling system cleaner designed for use with all types of diesel, petrol and LPG engines. Thermo-Tech Radiator Flush is a non-acidic, alkaline-based cleaner offering the following features:

- Removal of rust and scale
- Compatible with all coolant types
- Suitable for heavy-duty on and off-road applications



Thermo-Tech Radiator Flush is available in:

	RADIATOR FLUSH
5 Litres	P903116
20 Litres	P903117
205 Litres	-
1000 Litres	-

Contains 140g/L alkaline salts



Diesel Engine Coolant Maintenance Requires

- Low silicate antifreeze
- Good quality water
- Protective Coolant Additive
- Routine Coolant Concentration Testing

Test Strip Kit

Donaldson test kits offer a quick, one-minute test that helps you maintain that cooling system chemical balance. Donaldson recommends testing your coolant twice a year.

N. America (shown) Part No. **X007684**
(12 test strips per package)
Australia Part No. P901874 (4 strip),
X007103 (50 strips), P901873 (25 -4 strip box)



Cooling system service guidelines at service intervals or at flush and re-charge time.

Servicing up to 20 Gallons / 75.7 L

Install a new filter corresponding SCA/SCA+ units

Service Interval			0-5 gals	6-10 gals	11-15 gals	16-20 gals
@ Miles	@ KM	@ Hours	0-19 L	22.7-37.8L	41.6-46.7 L	60.6-75.7 L
5,000	8045	125 hrs	n/a	2 units	2 units	2 units
10,000	16,090	250 hrs	2 units	2 units	4 units	4 units
15,000	24,135	375 hrs	2 units	4 units	4 units	6 units
20,000	32,180	500 hrs	2 units	4 units	6 units	8 units
25,000	40225	625 hrs	2 units	4 units	8 units	12 units

*SCA or SCA+

Greater than 20 gallons / 75.7 liters

SCA/SCA+ additive replenishment recommendations

Cooling System Capacity		at 250 Hours		at 500 Hours	
21-30 gallons	79.5-113.6 liters	2 pints	0.9 liters	3 pints	1.4 liters
31-50 gallons	117.3-189.3 liters	3 pints	1.4 liters	5 pints	2.4 liters
51-75 gallons	193.0-283.9 liters	4 pints	1.9 liters	8 pints	3.8 liters
76-100 gallons	287.7-378.5 liters	5 pints	2.4 liters	10 pints	4.7 liters
101-150 gallons	382.3-567.8 liters	8 pints	3.8 liters	15 pints	7.1 liters
151-200 gallons	571.5-757.0 liters	10 pints	4.7 liters	20 pints	9.5 liters
201-250 gallons	760.8-946.3 liters	13 pints	6.2 liters	25 pints	11.8 liters
251-300 gallons	950.0-1135.5 liters	15 pints	7.1 liters	30 pints	14.2 liters
301-350 gallons	1189.3-1324.8 liters	18 pints	8.5 liters	35 pints	16.6 liters
351-400 gallons	1328.5-1514.0 liters	20 pints	9.5 liters	40 pints	18.9 liters

Actions Required After Testing



If your additive is

Below 1.2 units per 1 gallon / 3.8L

Replace the coolant filter and add 1 pint (.47L) of additive liquid per each 4 gallons /15.1L of coolant

Between 1.2 - 3 units per 1 gallon / 3.8L



Continue to replace the coolant filter at each oil drain interval.

Greater than 3 3 units per 1 gallon / 3.8L

Replace the coolant filter with a non-charged filter until the additive concentration falls below 3 units per 1 gallon/3.8 subsequent oil drain interval.



Proper Steps for Spin-on Coolant Filter Replacements

When a cooling system is serviced, coolant filters are replaced dry. They are not pre-filled with any fluids. After coolant filter installation, the coolant fluid mixture is poured into the radiator overflow reservoir.



1 Remove radiator cap; caution if hot or under pressure



2 Unscrew and remove old filter and gasket



3 Wipe filter head with clean cloth



4 Apply thin film of clean motor oil to gasket



5 Align threads; spin filter on until gasket contact



6 Follow icons on filter to tighten



7 Pour coolant mix into overflow



8 Start engine and check for leaks



9 Test coolant according to type

SERVICE TRAINING VIDEOS





Cooling System Problems & Failures

There are many cooling system problems and failures. Most of these problems have occurred due to incorrect information and maintenance practices. The following will address these problem areas by correcting the erroneous information and listing the proper maintenance practices.

The chart shown below is a listing of the six most common problems seen in today's cooling system. Along with each problem is a description of how it occurs, how it affects your engine and, most importantly, the cure.

Problem	How it Happens	What it Can Do	The Cure
Rust	Oxidation within the cooling system	Clog the system. Cause accelerated wear	The inhibitors in a quality Supplemental Coolant Additive (SCA) prevent oxidation.
Acidity	One of two items: Ethylene glycol antifreeze reacts with oxygen in the air and forms acids; a loose head gasket or other leakage can allow sulphuric acids formed by the burning of fuel to leak into the cooling system.	Corrode iron, steel and aluminum.	The SCA keeps salt minerals in suspension so they cannot deposit on the engine metal surfaces or clog passages.
Pitted Cylinder Liners	Constant vibration of the cylinder liner causes a momentary vacuum to form on its surface. Coolant boils into the vacuum and vapor bubbles implode on the surfaces of the liner, digging into unprotected liners.	Cause pits which can extend over time, through the thickness of the liner and allow coolant to enter the combustion chamber or crankcase.	The SCA coats the liner with a thin film to protect it from erosion without impacting heat transfer.
Foam	Foam – the aeration of coolant – occurs from air leakage into the system.	Adds to the cavitation erosion problem, particularly in areas of water pump impellers	Today's SCAs have an anti-foam agent to prevent formation of air bubbles. This foam prevention agent is effective at all temperatures, even during start-up.
Pitted Water Pump Impellers	Flow rates and turbulence are high at the impeller blade. This causes cavitation. In addition there is a possibility that abrasive particles are present in the system.	Cause loss of pump efficiency and total pump failure	The supplemental additives protect the impeller from cavitation erosion and the filter holds particulate matter to reduce abrasive wear on the cooling system components

Re-printed with permission of the Filters Manufacturer's Council : Technical Service Bulletin 88-1